

SUPERB METALS TEST REPORT

SCOPE OF WORK

TAS 125 UPLIFT RESISTANCE TESTING OF 26GA STEEL 1" MECHANICAL SEAM ROOF PANEL

REPORT NUMBER

S4651.03-450-18 R0

TEST DATE(S)

06/13/25 – 07/09/25

ISSUE DATE

08/20/25

REVISION DATE

08/22/25

PAGES

16

DOCUMENT CONTROL NUMBER

RT-R-AMER-Test-7806 (07/12/22)

© 2020 INTERTEK

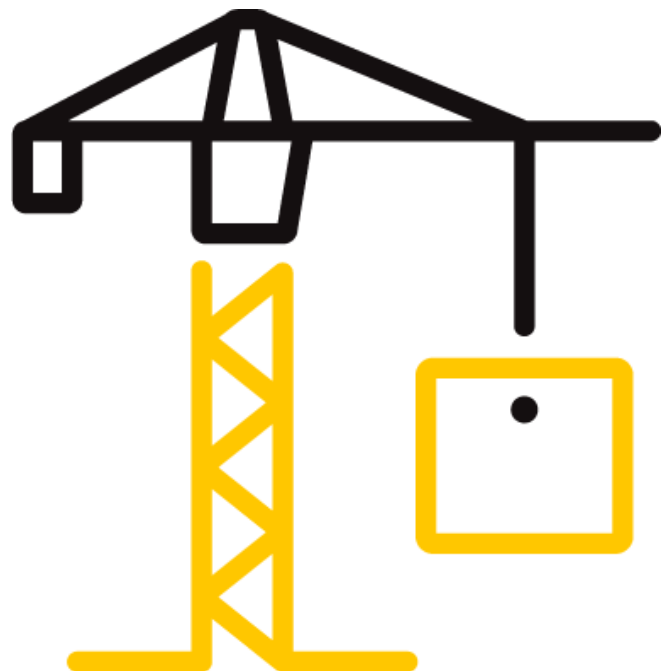

TEST REPORT FOR SUPERB METALS

Report No.: S4651.03-450-18 R0

Date: 08/20/25

Revision: 8/22/25

REPORT ISSUED TO SUPERB METALS

902 Jan Mar Ct. Suite A
Minneola, FL 34715

SECTION 1 SCOPE

Architectural Testing, Inc. (an Intertek company) dba Intertek Building & Construction (B&C) was contracted by Superb Metals to perform testing in accordance with TAS 125, *Standard Requirements for Metal Roofing Systems*, on their 26GA Steel 1" Mechanical Seam Roof Panels. Results obtained are tested values and were secured by using the designated test method(s). Uplift testing was conducted at the Intertek B&C test facility in West Palm Beach, FL. Tensile testing was conducted at Intertek B&C test facility in Lithia Springs, GA.

This report does not constitute certification of this product nor an opinion or endorsement by this laboratory. Intertek B&C will service this report for the entire test record retention period. The test record retention period ends ten years after the test date. Test records, such as detailed drawings, datasheets, representative samples of test specimens, or other pertinent project documentation, will be retained for the entire test record retention period.

Unless differently required, Intertek reports apply the "Simple Acceptance" rule, also called "Shared Risk approach," of ILAC-G8:09/2019, Guidelines on Decision Rules and Statements of Conformity.

For INTERTEK B&C:

COMPLETED BY:	Seth Allen	REVIEWED BY:	Tanya A. Dolby, P.E.
	Project Lead		Engineering Services
TITLE:	Laboratory Testing	TITLE:	Engineering Manager
SIGNATURE:		SIGNATURE:	
DATE:	08/22/25	DATE:	08/22/25

SA/TD:krf

This report is for the exclusive use of Intertek's Client and is provided pursuant to the agreement between Intertek and its Client. Intertek's responsibility and liability are limited to the terms and conditions of the agreement. Intertek assumes no liability to any party, other than to the Client in accordance with the agreement, for any loss, expense or damage occasioned by the use of this report. Only the Client is authorized to permit copying or distribution of this report and then only in its entirety. Any use of the Intertek name or one of its marks for the sale or advertisement of the tested material, product or service must first be approved in writing by Intertek. The observations and test results in this report are relevant only to the sample(s) tested. This report by itself does not imply that the material, product, or service is or has ever been under an Intertek certification program.

TEST REPORT FOR SUPERB METALS

Report No.: S4651.03-450-18 R0

Date: 08/20/25

Revision: 8/22/25

SECTION 2

SUMMARY OF TEST RESULTS

Product Type: Metal Roof Panel

Series/Model: 26GA Steel 1" Mechanical Seam

Specimen 1 - Ultimate Test Load Achieved: -307 psf

Specimen 2 - Ultimate Test Load Achieved: -202 psf

SECTION 3

TEST METHOD(S)

The specimens were evaluated in general accordance with the following:

TAS 125-03, *Standard Requirements for Metal Roofing Systems* Only two specimens were tested.

SECTION 4

MATERIAL SOURCE/INSTALLATION

Test specimens were provided by the client.

Installation of the tested product was performed the client.

SECTION 5

EQUIPMENT

Cycling and Static Load Mechanism: Computer controlled centrifugal blowers with electronic pressure measuring device.

Deflection Measuring Device: Linear Transducers

SECTION 6

LIST OF OFFICIAL OBSERVERS

NAME	COMPANY
Joseph Lukas	Superb Metals
Bruce Johnson	Superb Metals
Seth Allen	Intertek B&C
Charles Gilbert	Intertek B&C

TEST REPORT FOR SUPERB METALS

Report No.: S4651.03-450-18 R0

Date: 08/20/25

Revision: 8/22/25

SECTION 7

TEST PROCEDURE

This test evaluates the comparative resistance of roof assemblies to positive and negative pressures by simulating the effects of wind gusts by use of oscillating exterior pressure and constant interior pressures. Three assemblies were tested per TAS 125 at each class rating. (Reference Chart No. 1 for test pressures and load durations.) The measurements were taken via linear transducers.

TEST PHASE	DURATION minutes	NEGATIVE PRESSURE		POSITIVE PRESSURE	
		POUNDS PER SQUARE FOOT psf (kPa)	INCHES OF WATER inches (mm)	POUNDS PER SQUARE FOOT psf (kPa)	INCHES OF WATER inches (mm)
Class 30					
1	5	16.2 (0.79)	3.1 (79)	0.0 (0.00)	0.0 (0)
2	5	16.2 (0.79)	3.1 (79)	13.8 (0.66)	2.7 (69)
3	60	8.1 - 27.7 (0.39 - 1.33)	1.5 - 5.3 (38 - 135)	13.8 (0.66)	2.7 (69)
4	5	24.2 (1.16)	4.7 (119)	0.0 (0.00)	0.0 (0)
5	5	24.2 (1.16)	4.7 (119)	20.8 (1.00)	4.0 (102)
Class 60					
1	5	32.3 (1.55)	6.2 (157)	0.0 (0.00)	0.0 (0)
2	5	32.3 (1.55)	6.2 (157)	27.7 (1.33)	5.3 (135)
3	60	16.2 - 55.4 (0.79 - 2.66)	3.1 - 10.7 (79 - 272)	27.7 (1.33)	5.3 (135)
4	5	40.4 (1.94)	7.8 (198)	0.0 (0.00)	0.0 (0)
5	5	40.4 (1.94)	7.8 (198)	34.6 (1.66)	6.7 (170)
Class 90 (maximum combined uplift pressure of 105 psf)					
1	5	48.5 (2.33)	9.3 (236)	0.0 (0.00)	0.0 (0)
2	5	48.5 (2.33)	9.3 (236)	41.5 (1.99)	8.0 (203)
3	60	24.2 - 48.5 (1.16 - 2.33)	4.7 - 9.3 (119 - 236)	41.5 (1.99)	8.0 (203)
4	5	56.5 (2.71)	10.9 (277)	0.0 (0.00)	0.0 (0)
5	5	56.5 (2.71)	10.9 (277)	48.5 (2.33)	9.3 (236)

**Chart No. 1
TAS 125 Load Table Test Pressures**

TEST REPORT FOR SUPERB METALS

Report No.: S4651.03-450-18 R0

Date: 08/20/25

Revision: 8/22/25

SECTION 8

TEST SPECIMEN DESCRIPTION

Product Type: Metal Roof Panels

Series/Model: 26GA Steel 1" Mechanical Seam

Product Size(s):

All Test Specimens

OVERALL AREA:	WIDTH		HEIGHT	
	millimeters	inches	millimeters	inches
9.3 m ² (100.0 ft ²)				
Overall Size	3048	120	3048	120
Panel Size	432	17	3048	120

The following description applies to all specimens.

Test Deck Construction:

The 10' 0" wide by 10' 0" long by 1' 3" deep test frame was fabricated from C15 by 33.9 steel channels. The test frame utilized six joists constructed from Southern Yellow Pine 2 x 12 nominal lumber located on two sides of the test frame and spaced 24" on center. The joists were secured to the test frame using two 1/2" x 3" long bolts with washers and nuts through an 8" long, 2" by 4" by 1/8" steel angle with pre-drilled fastener locations. The steel angles were welded to the test frame 24" on center. Southern Yellow Pine 2 x 12 nominal lumber was utilized as cross members at the midspan of the joists. The cross members were secured to the joists using #8 x 3" long Torx Flat screws at each end. The deck was sheathed with 15/32" thick plywood. The plywood was secured using 8d coated ring shank nails spaced 6" on center.

TEST REPORT FOR SUPERB METALS

Report No.: S4651.03-450-18 R0

Date: 08/20/25

Revision: 8/22/25

Specimen #1 Roof System:

COMPONENTS	DETAILS	ATTACHMENT METHOD
Peel & Stick Underlayment	A single layer of Peel & Stick was used with a 3" overlap between adjacent sheets.	Self-adhered.
Clip	The 2" long x 1-1/8" tall clips were constructed from 26Ga steel.	The clips were spaced at 12" on center and attached using two #12 x 1" panclip fasteners per clip.
1" 180° Mechanical Seam	The panels were constructed from 26GA Steel and had a 17" coverage width. Seven full panels were tested	The male leg of the panels were secured with clips spaced 12" on center. The female leg of the panels was placed over the male leg of the panel and mechanically seamed 180°. The perimeter was secured with #12 x 1" panclip fasteners spaced 2" on center at the ends and 2" on center at the sides.

Specimen #2 Roof System:

COMPONENTS	DETAILS	ATTACHMENT METHOD
Peel & Stick Underlayment	A single layer of Peel & Stick was used with a 3" overlap between adjacent sheets.	Self-adhered.
Clip	The 2" long x 1-1/8" tall clips were constructed from 26Ga steel.	The clips were spaced at 24" on center and attached using two #12 x 1" panclip fasteners per clip.
1" 180° Mechanical Seam	The panels were constructed from 26GA Steel and had a 17" coverage width. Seven full panels were tested	The male leg of the panels were secured with clips spaced 24" on center. The female leg of the panels was placed over the male leg of the panel and mechanically seamed 180°. The perimeter was secured with #12 x 1" panclip fasteners spaced 2" on center at the ends and 2" on center at the sides.

TEST REPORT FOR SUPERB METALS

Report No.: S4651.03-450-18 R0

Date: 08/20/25

Revision: 8/22/25

SECTION 9

UPLIFT TEST RESULTS

The temperature during testing was 29°C (85°F). The results are tabulated as follows.

Test Specimen #1

TEST TITLE	OBSERVATIONS	DEFLECTION MEASUREMENTS	RESULTS
Class 30, Phases 1-5	No Visible Damage to System	Reference Table No. 1	PASSED
Class 60, Phases 1-5	No Visible Damage to System	Reference Table No. 1	PASSED
Class 90, Phases 1-5	No Visible Damage to System	Reference Table No. 1	PASSED
Supplemental Loads -112 psf to -307 psf	No Visible Damage to System	Reference Table No. 2	PASSED
Supplemental Loads -322 psf	Fastener Failure	Reference Table No. 2	FAILED

Test Specimen #2

TEST TITLE	OBSERVATIONS	DEFLECTION MEASUREMENTS	RESULTS
Class 30, Phases 1-5	No Visible Damage to System	Reference Table No. 5	PASSED
Class 60, Phases 1-5	No Visible Damage to System	Reference Table No. 5	PASSED
Class 90, Phases 1-5	No Visible Damage to System	Reference Table No. 5	PASSED
Supplemental Loads -112 psf to -202 psf	No Visible Damage to System	Reference Table No. 6	PASSED
Supplemental Loads -217 psf	Fastener Failure	Reference Table No. 6	FAILED

Notes:

Reference Chart No. 1 for test pressures and load durations.

Reference Sketch No. 1 for location of deflection measurement devices.

A loose fitting, pleated 4-mil plastic film was utilized to assist in obtaining uniform pressure on the roof system. The plastic film was located between the moisture barrier and the roof panels to facilitate testing. In our opinion, this did not influence test results.

SECTION 10

CONCLUSION

The 26GA 1" Mechanical Seam tested per TAS 125 achieved an ultimate test load of:

Specimen 1: -307 psf

Specimen 2: -202 psf

TEST REPORT FOR SUPERB METALS

Report No.: S4651.03-450-18 R0

Date: 08/20/25

Revision: 8/22/25

SECTION 11 SKETCH

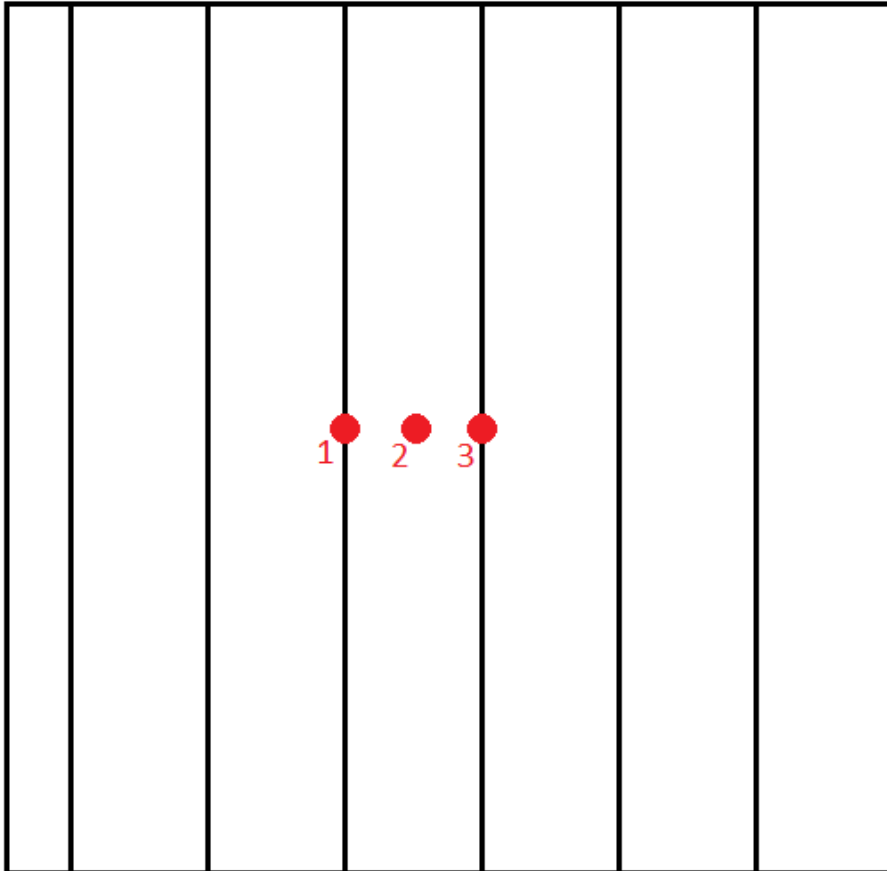

Sketch No. 1
Deflection Measurement Device Locations

TEST REPORT FOR SUPERB METALS

Report No.: S4651.03-450-18 R0

Date: 08/20/25

Revision: 8/22/25

**SECTION 12
TABLES**

CLASS	PHASE	DEFLECTION MEASUREMENTS (inches)		
		INDICATOR		
		#1	#2	#3
30	1	0.04	0.40	0.04
	2	0.07	1.06	0.06
	3 Minimum	0.08	1.11	0.07
	3 Maximum	0.11	1.15	0.10
	4	0.10	1.14	0.10
	5	0.13	1.23	0.13
	Final (0.0 psf)	0.06	0.94	0.05
60	1	0.11	1.34	0.11
	2	0.16	1.44	0.17
	3 Minimum	0.18	1.61	0.17
	3 Maximum	0.24	1.71	0.24
	4	0.18	1.74	0.17
	5	0.24	1.85	0.24
	Final (0.0 psf)	0.11	1.20	0.09
90	1	0.20	1.80	0.19
	2	0.29	2.09	0.28
	3 Minimum	0.28	1.95	0.27
	3 Maximum	0.31	2.05	0.30
	4	0.28	2.10	0.26
	5	0.38	2.50	0.37
	Final (0.0 psf)	0.18	1.21	0.12

**Table No. 1
Deflection Measurements – Test Specimen #1**

TEST REPORT FOR SUPERB METALS

Report No.: S4651.03-450-18 R0

Date: 08/20/25

Revision: 8/22/25

VACUUM (psf)	UPLIFT (psf)	LOAD (psf)	SUPPLEMENTAL DEFLECTION MEASUREMENTS (inches)		
			INDICATOR		
			#1	#2	#3
-63.5	-48.5	-112.0	0.41	2.60	0.40
-78.5	-48.5	-127.0	0.47	2.78	0.47
-93.5	-48.5	-142.0	0.54	2.93	0.55
-108.5	-48.5	-157.0	0.65	3.12	0.67
-123.5	-48.5	-172.0	0.72	3.23	0.74
-138.5	-48.5	-187.0	0.81	3.36	0.74
-153.5	-48.5	-202.0	0.88	3.47	0.74
-168.5	-48.5	-217.0	0.97	3.56	0.74
-183.5	-48.5	-232.0	1.04	3.63	0.74
-198.5	-48.5	-247.0	1.11	3.69	0.74
-213.5	-48.5	-262.0	1.22	3.91	0.74
-228.5	-48.5	-277.0	1.33	4.00	0.74
-243.5	-48.5	-292.0	1.58	4.00	0.74
-258.5	-48.5	-307.0	1.67	4.00	0.74
-273.5	-48.5	-322.0	Failure		

Table No. 2
Supplemental Deflection Measurements – Test Specimen #1

TEST REPORT FOR SUPERB METALS

Report No.: S4651.03-450-18 R0

Date: 08/20/25

Revision: 8/22/25

CLASS	PHASE	DEFLECTION MEASUREMENTS (inches)		
		INDICATOR		
		#1	#2	#3
30	1	0.01	0.12	0.02
	2	0.04	0.33	0.05
	3 Minimum	0.04	0.38	0.07
	3 Maximum	0.06	0.40	0.09
	4	0.04	0.46	0.10
	5	0.09	0.52	0.16
	Final (0.0 psf)	0.01	0.10	0.06
60	1	0.07	0.55	0.13
	2	0.15	0.56	0.22
	3 Minimum	0.19	0.56	0.25
	3 Maximum	0.27	0.56	0.33
	4	0.19	0.69	0.25
	5	0.29	0.56	0.35
	Final (0.0 psf)	0.09	0.24	0.15
90	1	0.21	0.72	0.28
	2	0.35	0.72	0.43
	3 Minimum	0.33	0.72	0.40
	3 Maximum	0.37	0.72	0.44
	4	0.28	0.62	0.23
	5	0.47	0.69	0.54
	Final (0.0 psf)	0.20	0.50	0.27

Table No. 3
Deflection Measurements – Test Specimen #2

TEST REPORT FOR SUPERB METALS

Report No.: S4651.03-450-18 R0

Date: 08/20/25

Revision: 8/22/25

VACUUM (psf)	UPLIFT (psf)	LOAD (psf)	SUPPLEMENTAL DEFLECTION MEASUREMENTS (inches)		
			INDICATOR		
			#1	#2	#3
-63.5	-48.5	-112.0	0.53	1.00	0.61
-78.5	-48.5	-127.0	0.59	1.00	0.65
-93.5	-48.5	-142.0	0.66	1.00	0.72
-108.5	-48.5	-157.0	0.74	1.00	0.78
-123.5	-48.5	-172.0	0.89	1.00	0.87
-138.5	-48.5	-187.0	0.97	1.00	0.93
-153.5	-48.5	-202.0	1.07	1.00	1.00
-168.5	-48.5	-217.0	Failure		

Table No. 4

Supplemental Deflection Measurements – Test Specimen #2

TEST REPORT FOR SUPERB METALS

Report No.: S4651.03-450-18 R0

Date: 08/20/25

Revision: 8/22/25

SECTION 13

PHOTOGRAPHS



Photo No. 1
26GA Test Deck After Testing

TEST REPORT FOR SUPERB METALS

Report No.: S4651.03-450-18 R0

Date: 08/20/25

Revision: 8/22/25

SECTION 14 DRAWINGS

The test specimen drawings have been reviewed by Intertek B&C and are representative of the test specimen(s) reported herein. Test specimen construction was verified by Intertek B&C per the drawings included in this report. Any deviations are documented herein or on the drawings.

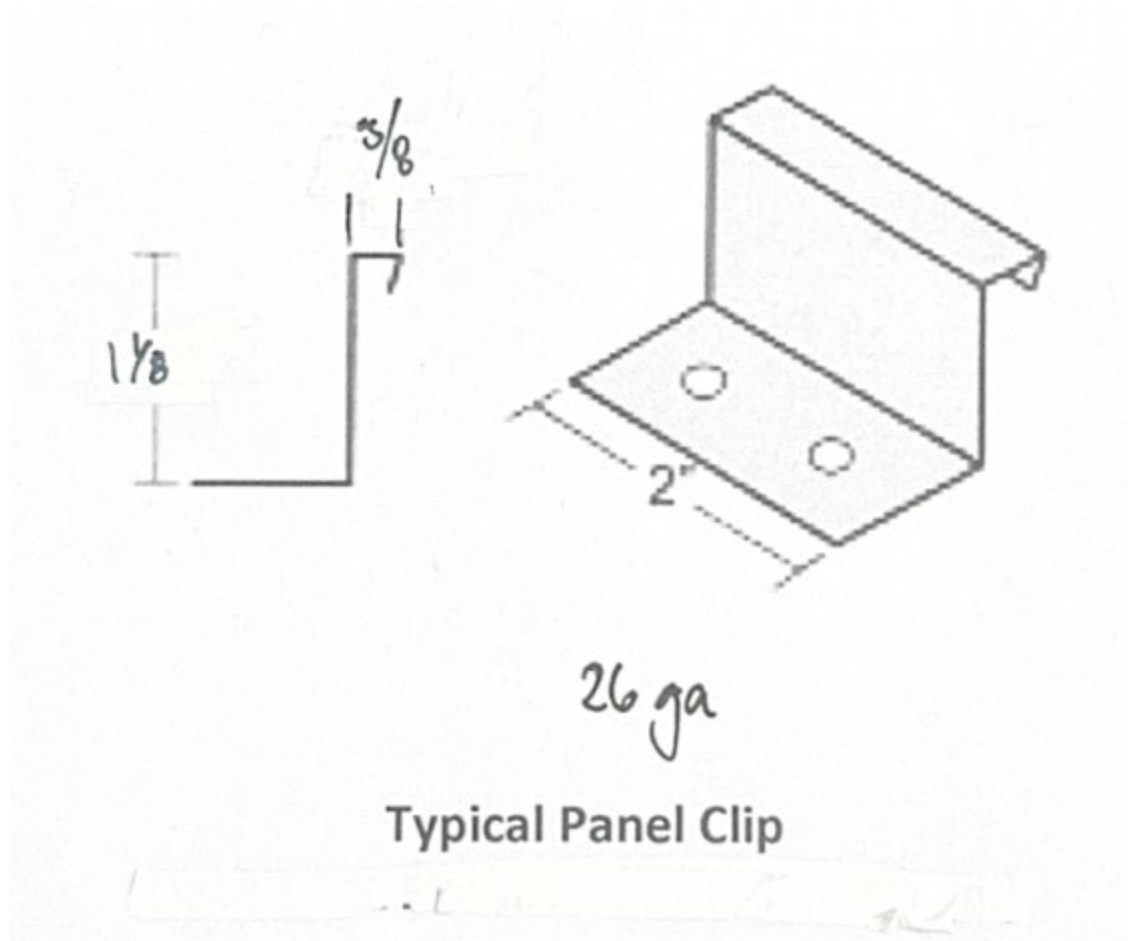

Drawing # 1
Clip Dimensions

TEST REPORT FOR SUPERB METALS

Report No.: S4651.03-450-18 R0

Date: 08/20/25

Revision: 8/22/25

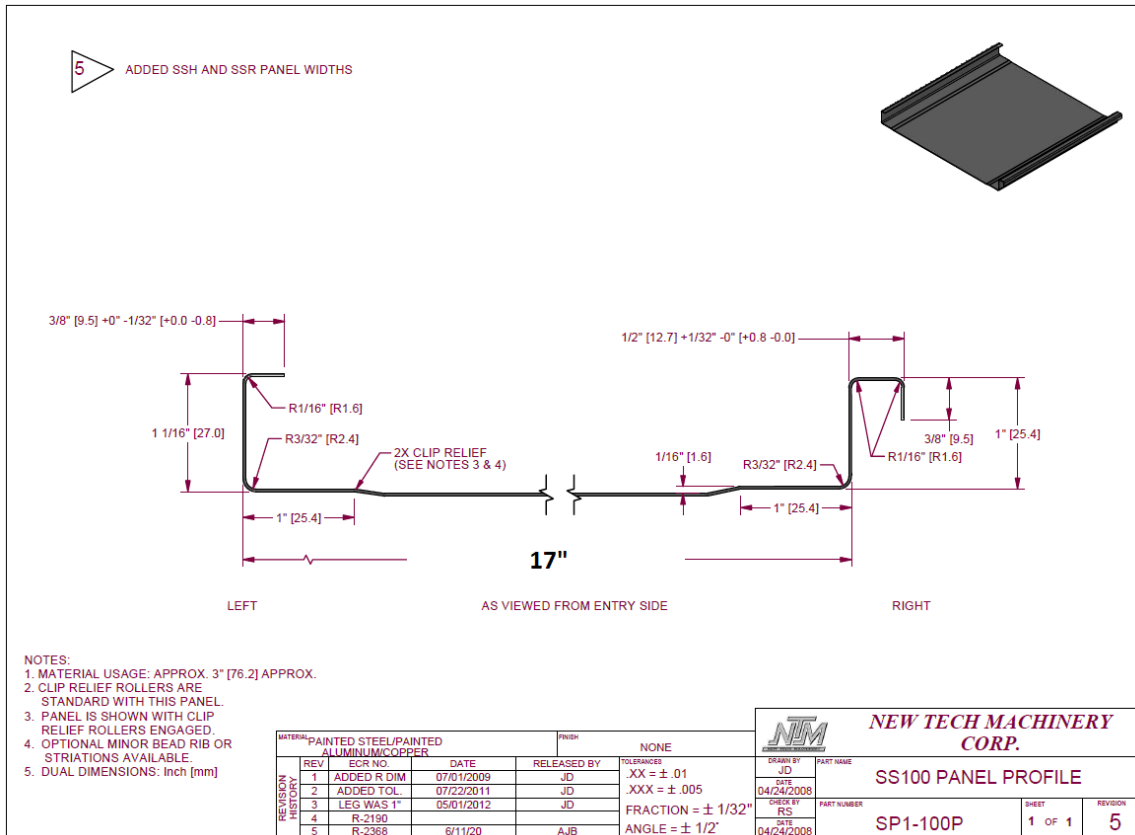

Drawing # 2
Panel Dimensions



Total Quality. Assured.

2658 Electronics Way
West Palm Beach, Florida 33407

Telephone: 561-881-0020
Facsimile: 717-764-4129
www.intertek.com/building

TEST REPORT FOR SUPERB METALS

Report No.: S4651.03-450-18 R0

Date: 08/20/25

Revision: 8/22/25

SECTION 15

REVISION LOG

REVISION #	DATE	PAGES	REVISION
0	08/20/25	N/A	Original Report Issue
1	08/22/25	6	Correct clip size